

# DIY Simple Rectangular Face Mask



Since everyone has been asked to wear face masks in public, YouTube and the Internet has become flooded with DIY instruction for making one's own face mask. There are a lot of great videos out there and I have watched a bunch of them. However no matter how hard I tried I could not get the pleats right. That and the thing kept sliding off my big nose. So I decided to enter the fray by drawing my own pattern so that I could better understand my problem.

This is NOT intended to be a N95 medical mask. The goal here is to produce a reusable, washable mask for 'the rest of us' to wear in public to reduce that chance of either spreading or catching the disease. I will leave the more complex and critical masks to the industrial experts and/or very skilled home crafters. This is a simplified design that has no pockets, binding tape, etc. It is sized so that it should fit most faces (*the 3/4 wide pleats let it expand a lot*). Because this only uses 2 pieces of 8-1/2 cloth you really should not need a cutting pattern. However one is provided if you want it. You will need to piece it together (*hint: the match line on the second sheet is in the exact middle of the sheet*).

This document/file is placed in the **PUBLIC DOMAIN**.

Disclaimer: The author assumes no liability for the accuracy, fitness or application of the information or design(s) herein.  
Lewis Balentine, Houston, Texas, 11 April 2020

## Notes: (11 April 2020)

If you find the masks are a bit too wide or too short then changing the width should be fairly simple. Note the difference between the “SMALL-NARROW” and “SMALL” masks in the attached patterns.

An optional nose piece pocket can be added if desired. It should be sewn to the ‘right side’ of the front face mask panel before sewing the two panels together.

“Smart Air” has a good reference “What Are The Best Materials for Making DIY Masks?” that can be accessed at the following URL:

<https://smartairfilters.com/en/blog/best-materials-make-diy-face-mask-virus/#>

The original **PDF** file for this document can be found at my website on the page:

<http://www.keywild.com/facemask>

There is also a ZIP file with all the original CAD files in AutoCAD V13 compatible **DWG** format. Those CAD files were produced with the cad software “**BricsCAD Pro**” Version 18.2. This is one of the few professional CAD systems available that runs under Linux.

[https://www.bricsys.com/?site=en\\_US](https://www.bricsys.com/?site=en_US)

Separate PDF files were combined into a single PDF document using the software “Master PDF Editor” build 5.3.22

<https://code-industry.net/>

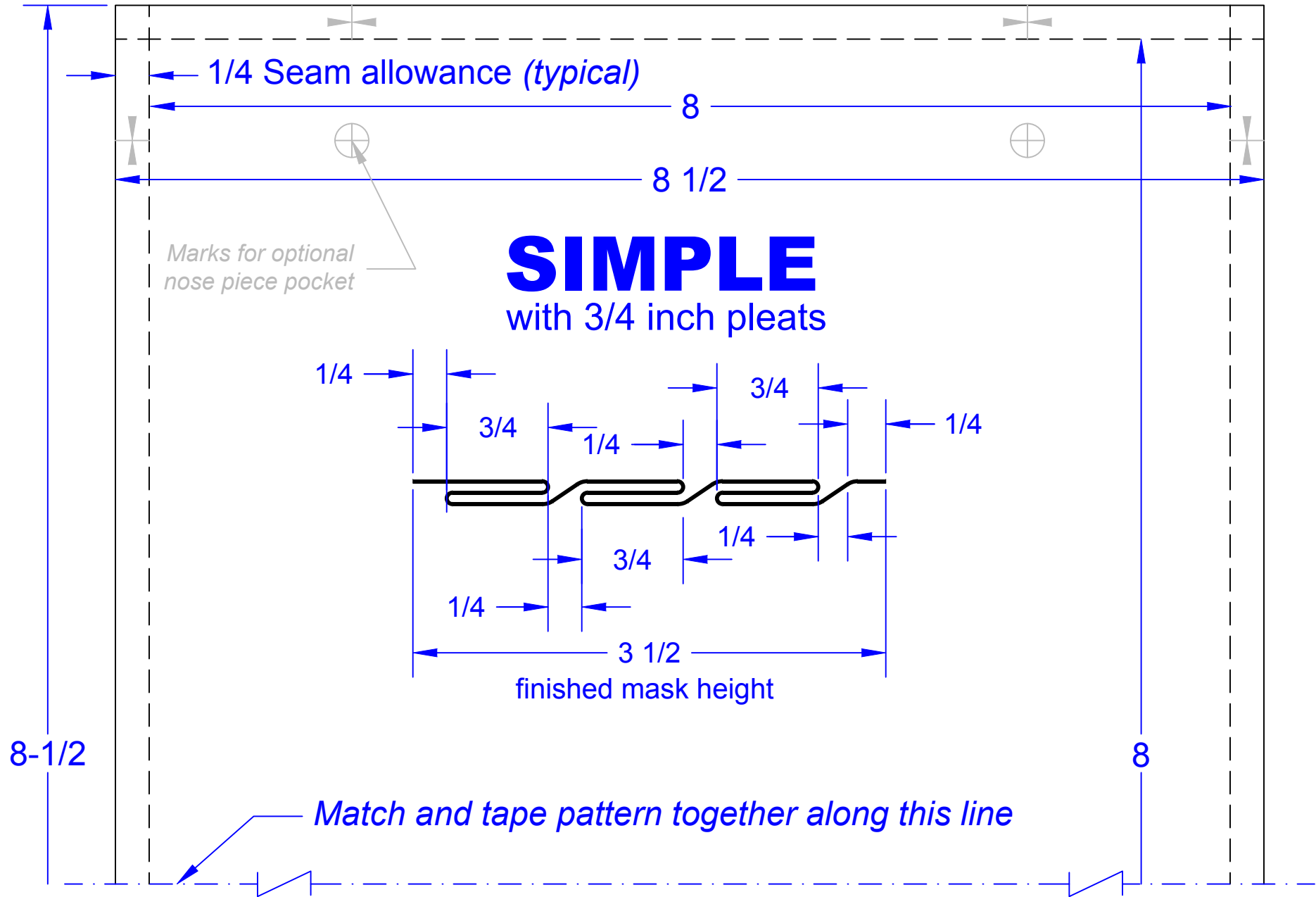
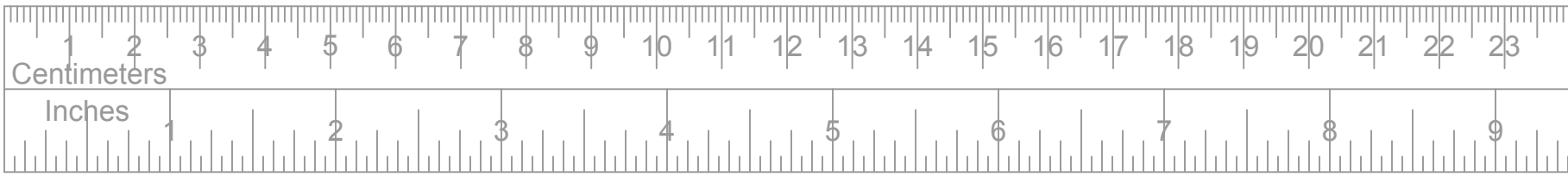

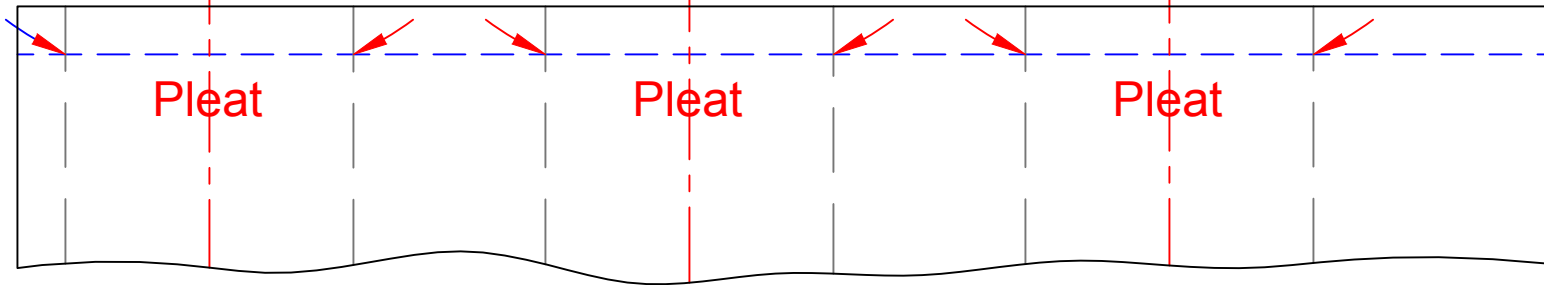
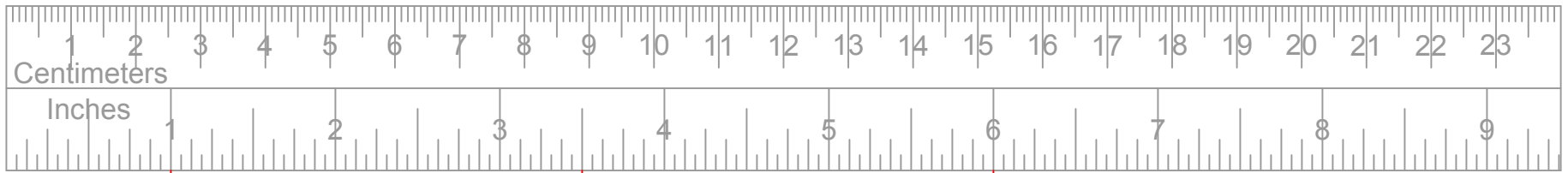

## Pleat Template



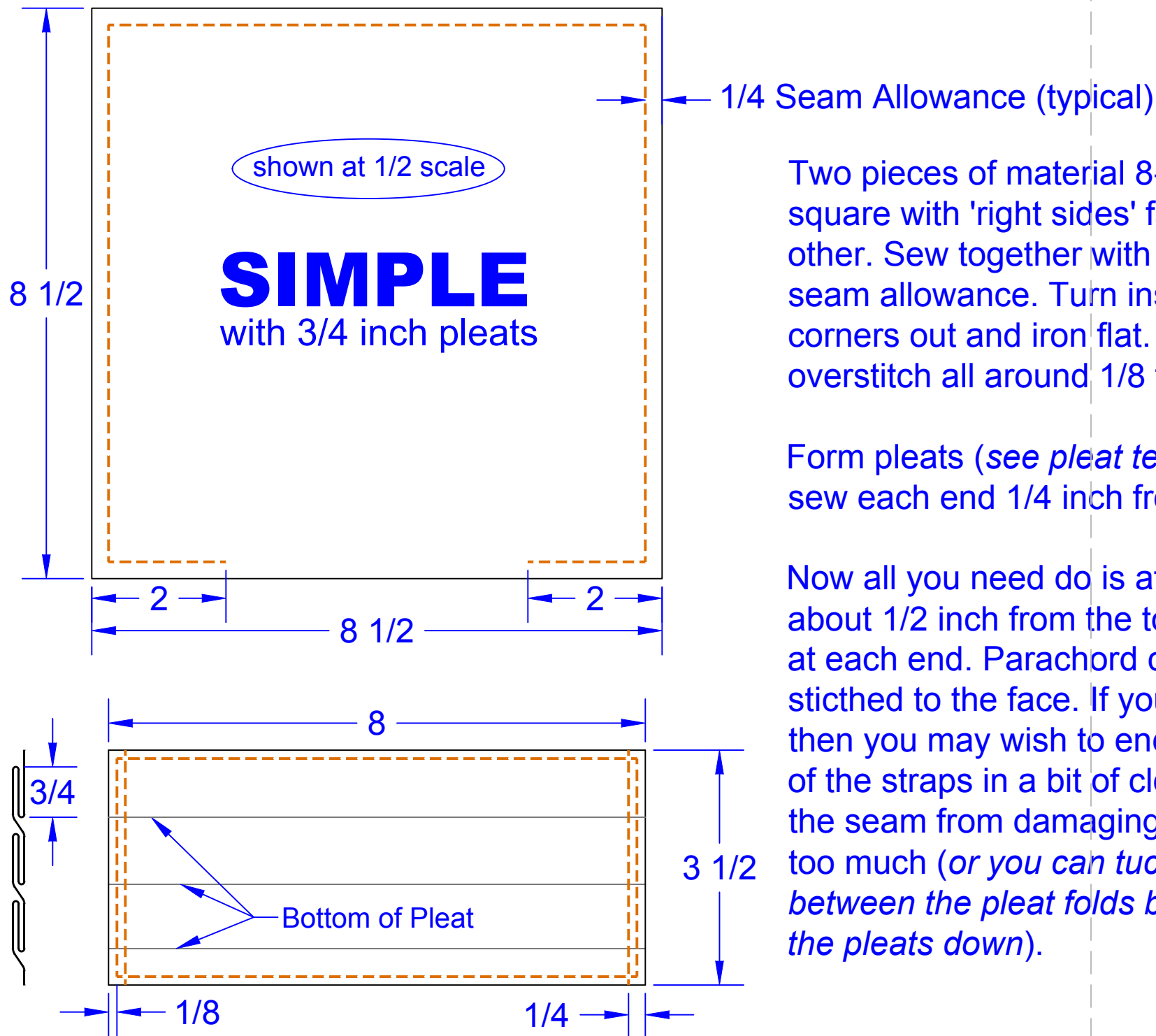

Two pieces of material 8-1/2 inches square with 'right sides' facing each other. Sew together with 1/4 inch seam allowance. Turn inside out, poke corners out and iron flat. Then overstretch all around 1/8 from edge.

Form pleats (see *pleat template*) and sew each end 1/4 inch from edge.

Now all you need do is attach straps about 1/2 inch from the top and bottom at each end. Parachord can be directly stitched to the face. If you use elastic then you may wish to enclose the ends of the straps in a bit of cloth to keep the seam from damaging the straps too much (*or you can tuck them between the pleat folds before sewing the pleats down*).